

SR.2X4™

EXPANDED POLYSTYRENE RIGID INSULATION FOR FOUNDATIONS

The SR.2X4™ panels manufactured by Styro Rail™ offer an alternative to traditional insulation of basement walls. They are produced in type 1 expanded polystyrene [EPS] rigid insulation. Each panel is comprised with grooves at every 406 mm [16"] o.c. or 610 mm [24"] o.c. in order to facilitate the insertion of wood stud framing. Metal brackets are provided to firmly secure the wood stud framing to the concrete wall.

RECOMMENDED USE

Install SR.2X4™ panels on the interior surface of foundation walls in order to obtain a continuous thermal envelope. Suitable for renovation projects and new construction.

PANEL COMPOSITION/DESCRIPTION

- A** Type 1 Expanded Polystyrene Rigid Panel Insulation [EPS] manufactured by Styro Rail™
- B** Metal brackets: 6 brackets for panels of 2.4 m [8'] and 9 brackets for panels of 2.7 m [9']
- C** Channels
- D** Pre-cut lines
- E** Filling block [for new construction installation]

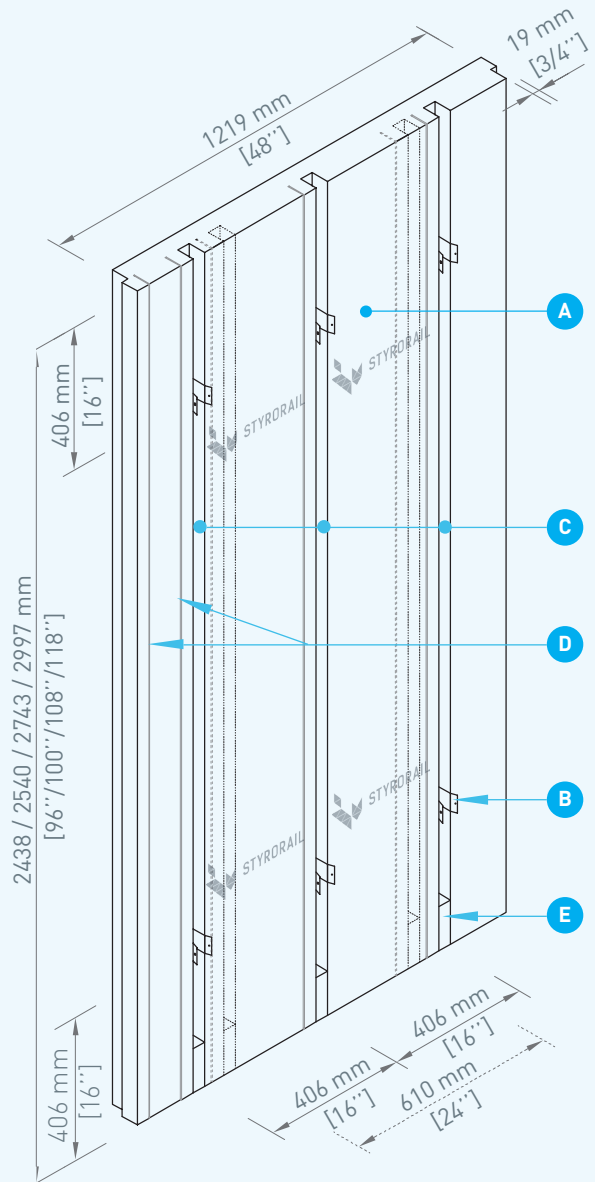

PANEL INSTALLATION

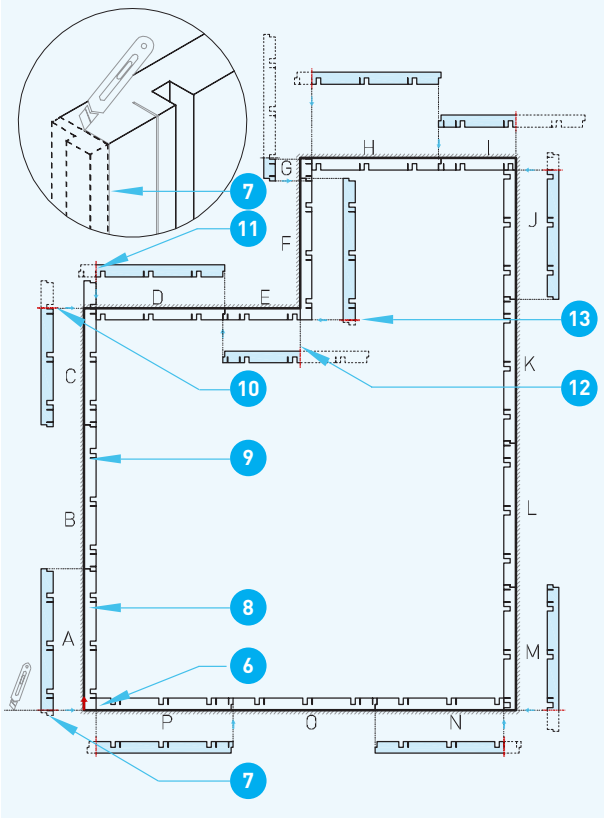
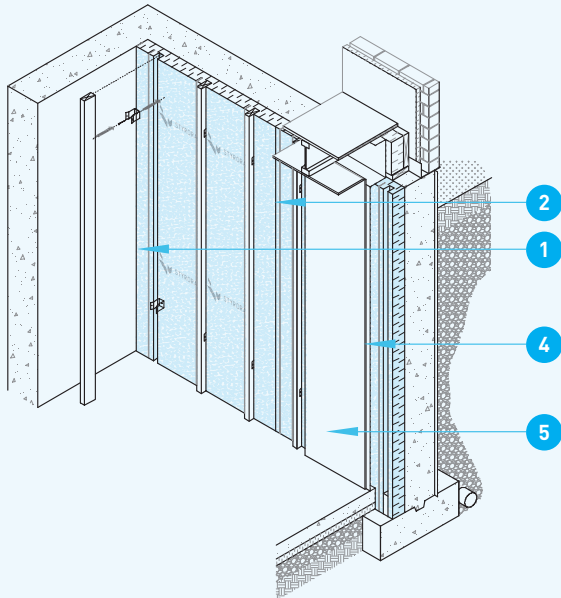

GENERAL INSTALLATION

- 1 Install panels on the interior surface of the foundation wall, in order to see the channels. Start from an inside corner, from left to right.
- 2 Butt ends between panels. Install panels continuously and uniformly.
- 3 Follow the steps and the installation diagram described in this guide to fix panels and studs.
- 4 Install and seal a vapor barrier.
- 5 Install a protective barrier such as gypsum boards.

INSTALLATION DIAGRAM

- 6 Start the installation in an inside corner.
- 7 Cut the panel [A] using a knife with a retractable blade. Cut on the first pre-cutline in order to eliminate the ship lap.
- 8 Install the cut panel [A] on the foundation wall, against the inside corner.
- 9 Install the panel [B].
- 10 At the inside corner, cut the panel [C] to the necessary width so that the panel abuts against the corner of the foundation wall. Install panel [C].
- 11 Cut the panel [D] at the second pre-cut line. Install panel [D].
- 12 At the outside corner, cut the panel [E] so that the end of the panel is aligned with the outside corner of the foundation wall.
- 13 Cut the panel [F] on the first pre-cut line in order to eliminate the ship lap. Install the panel [F].
- 14 Install all the panels as per the installation method described in this guide.

Note: New construction installation shown.

PANEL INSTALLATION

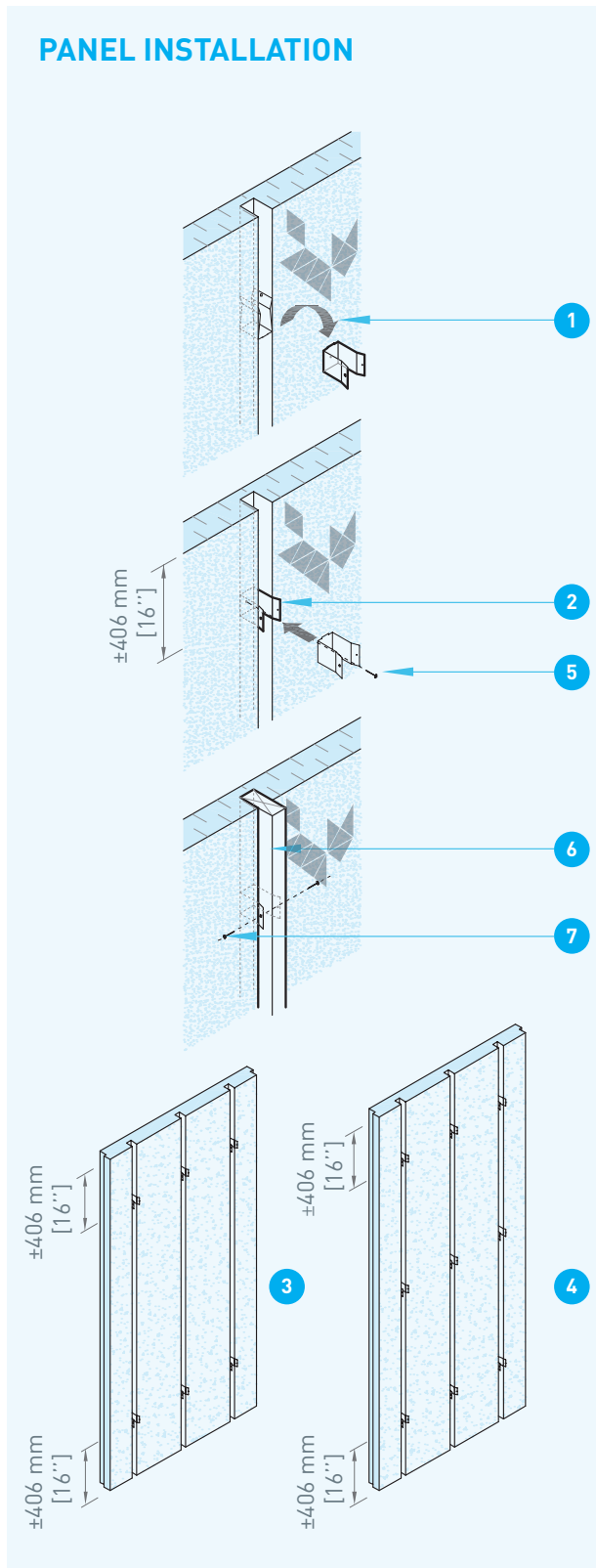

GENERAL FIXATION

- 1 Rotate the metal brackets as shown.
- 2 Insert the bracket into the channel. Allow a distance of approx. 406 mm [16"] between brackets and the upper and lower edges of the panel.
- 3 For the 2,438 m [8'] panels install 6 brackets as shown.
- 4 For the 2,743 m [9'] panels install 9 brackets as shown.
- 5 Nail the metal brackets on the foundation wall, through the panel using a concrete air gun. Use concrete nails of 57 mm [2-1/4"] for 76 mm [3"] panels, 83 mm [3-1/4"] for 102 mm [4"] panels and 95 mm [3-3/4"] for 114 mm [4-1/2"] panels.
- 6 Insert 38 mm x 89 mm [2"x4"] studs in each channel; the brackets located underneath the studs. Level the studs.
- 7 Fix the studs to the lateral sides of the brackets. Use #8 wood screws of 25 mm [1"].

PANEL INSTALLATION

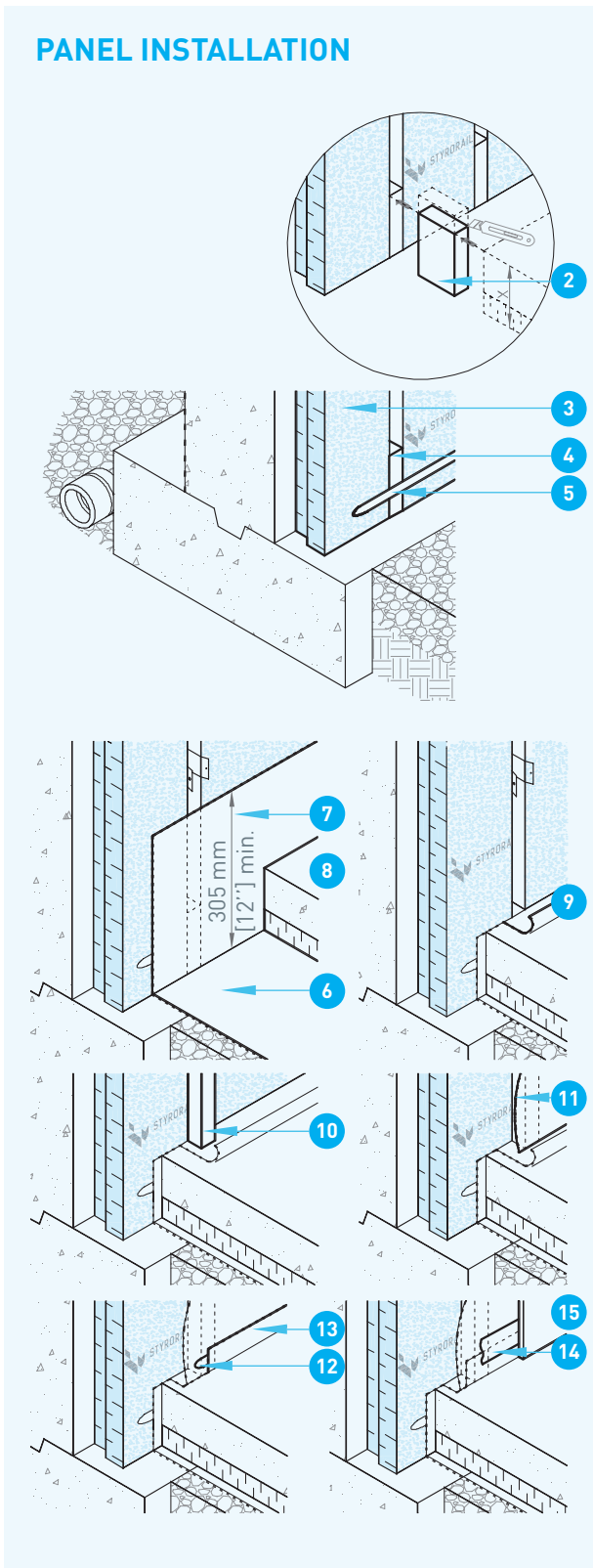

FOUNDATION WALL
[NEW CONSTRUCTION]

- 1 Remove the filling blocks.
- 2 Cut the blocks as per the thickness of the concrete slab and the insulation underneath the slab [x].
- 3 Install the panels directly on the footings, before the concrete slab pouring and as per the installation diagram described in this guide.
- 4 Install the cut blocks into the lower part of each channel in order to limit the concrete pouring into the channel.
- 5 Apply an acoustic sealant[†] bead at the bottom of the panel.
- 6 Install and seal a vapor barrier on the soil and on the footing.
- 7 Leave a minimum 305 mm [12"] strip at the bottom of the wall. Fold back the strip on the wall. Temporarily secure with an adhesive tape.
- 8 Install expanded polystyrene insulating panels on the ground, over the vapor barrier. Pour the concrete slab.
- 9 Fold forward the vapor barrier on the concrete slab.
- 10 Install studs as per the installation method described in this guide.
- 11 Install and seal a vapor barrier, above the studs.
- 12 Apply an acoustic sealant[†] bead between the two vapor barrier in order to seal effectively the junctions.
- 13 Fold back the vapor barrier of the concrete slab on the wall vapor barrier.
- 14 Seal the junctions of the vapor barrier at the bottom section of the wall with a compatible sealing tape.
- 15 Install a protective barrier such as gypsum boards.

PANEL INSTALLATION

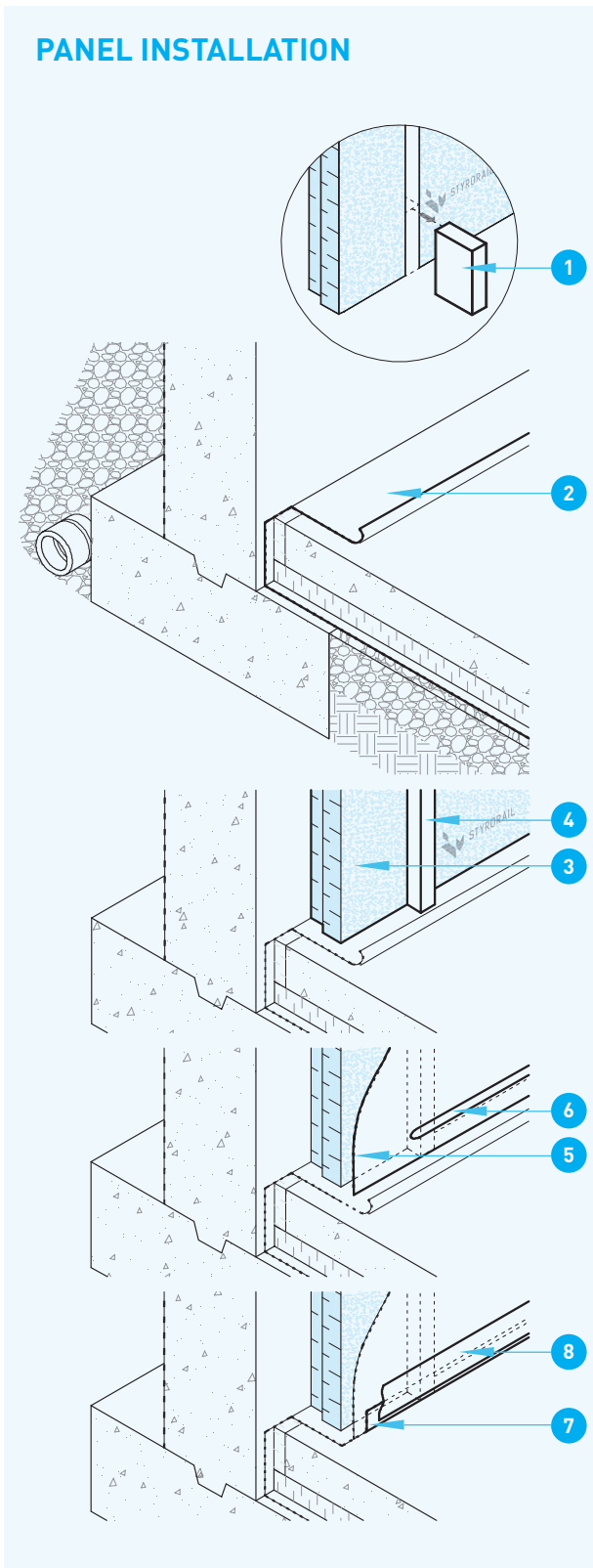

FOUNDATION WALL
[RENOVATION]

EXISTING CONCRETE SLAB WITH VAPOR BARRIER

- 1 Remove the filling blocks. Dispose.
- 2 If a vapor barrier strip exceeds at the bottom of the foundation wall; fold forward on the concrete slab before the panel's installation.
- 3 Install the panels on the concrete slab, over the vapor barrier strip. Install all the panels as per the installation diagram described in this guide.
- 4 Install the studs as per the installation method described in this guide.
- 5 Install and seal the vapor barrier above the studs.
- 6 Apply an acoustic sealant[†] bead between the two vapor barrier in order to effectively seal the junctions.
- 7 Fold back the vapor barrier of the concrete slab.
- 8 Seal the junctions of the vapor barrier at the bottom section of the wall with a compatible sealing tape.

PANEL INSTALLATION

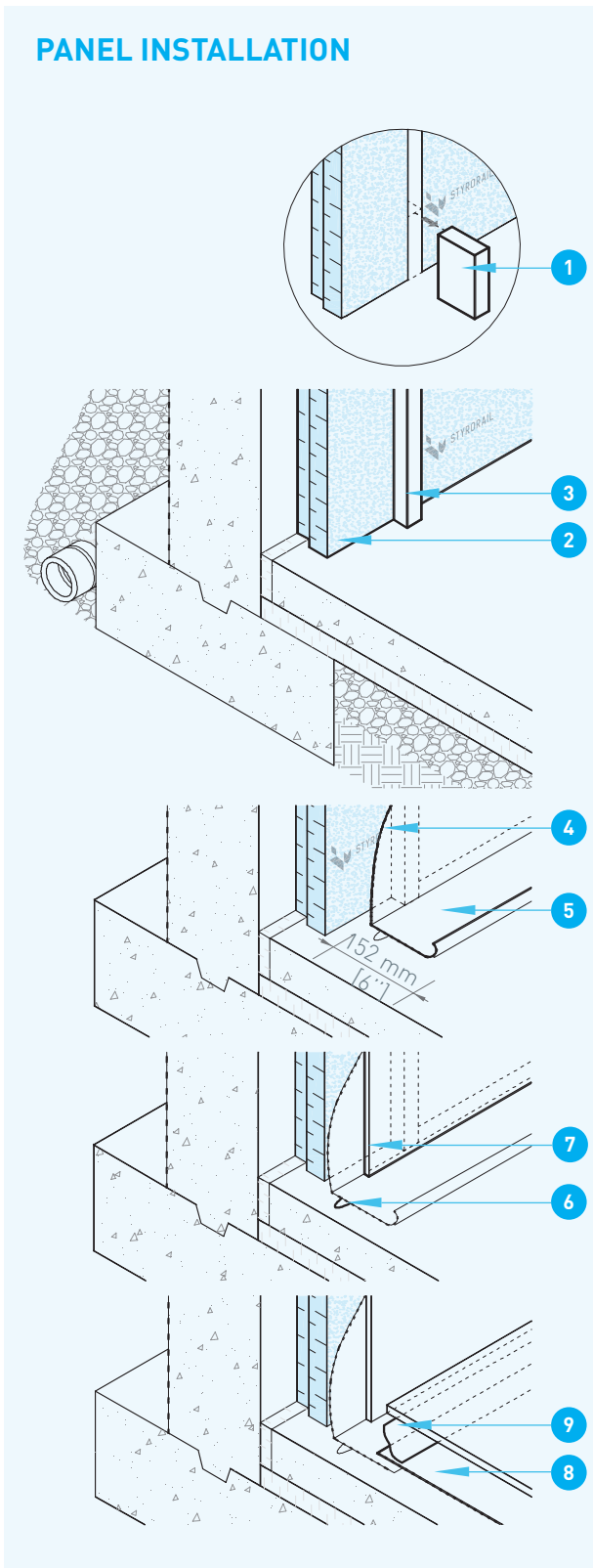

FOUNDATION WALL
[RENOVATION]

EXISTING CONCRETE SLAB WITHOUT VAPOR BARRIER

- 1 Remove the filling blocks. Dispose.
- 2 Install the panels directly on the concrete slab. Install all panels as per the installation diagram described in this guide.
- 3 Install the studs as per the installation method described in this guide.
- 4 Install and seal the vapor barrier.
- 5 Leave a minimum of 152 mm [6"] strip at the bottom of the wall and above the concrete slab.
- 6 Apply an acoustic sealant[†] bead between the concrete slab and the vapor barrier.
- 7 Install a protective barrier such as gypsum boards.
- 8 During the floor installation, install a vapor barrier underneath the finished floor.
- 9 Seal the vapor barrier joints with compatible sealing tape.

PANEL INSTALLATION

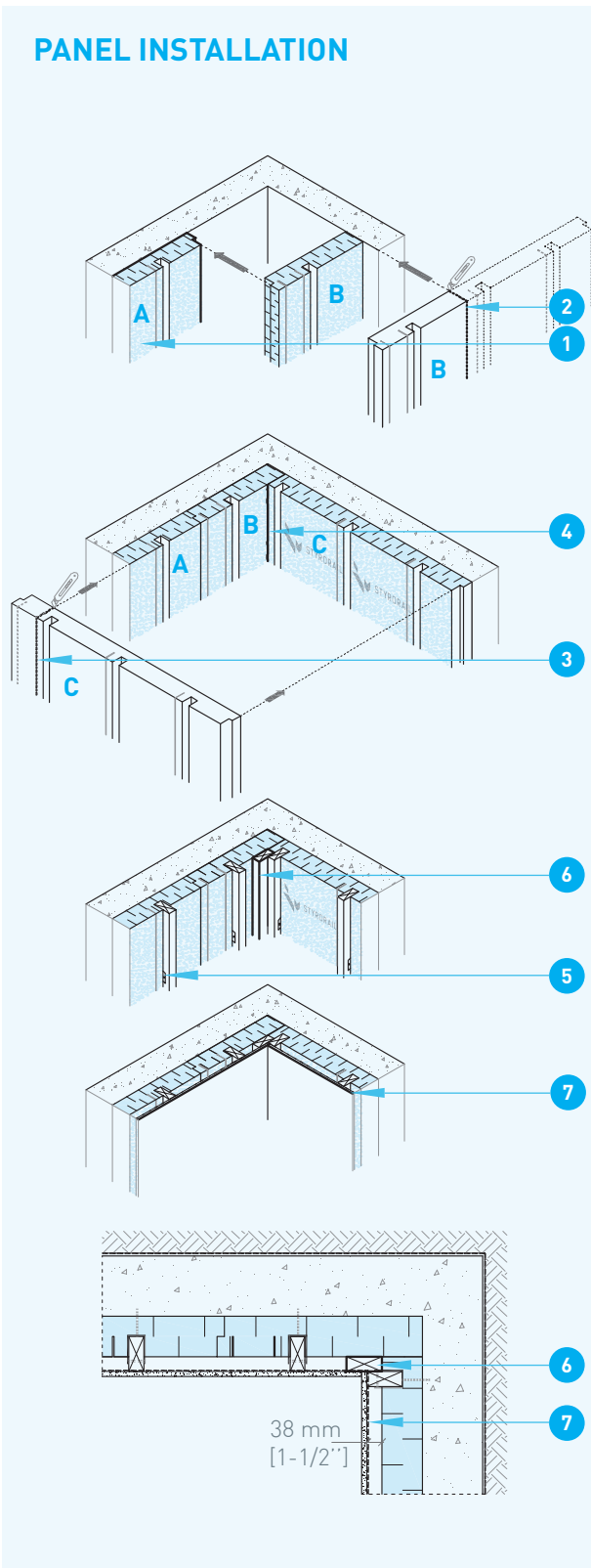

INSIDE CORNER

- 1 Start installation on the left side [panel A].
- 2 Cut the panel [B] to adjust for the dimension of the insulating wall. Cut with a knife with retractable blade. Install panel [B].
- 3 Cut the panel [C] on the second pre-cut line. Install panel [C].
- 4 Spray a urethane bead⁺⁺ at the corner in order to fill the cavity which may have formed during the insulation cutting.
- 5 Install the brackets and the studs as per the installation method described in this guide.
- 6 Insert and fix a 38 mm x 89 mm [2" x 4"] stud on the corner as shown in order to serve as backing for the protective barrier [gypsum board].
- 7 Install a vapor barrier and a protective barrier such as gypsum boards.

PANEL INSTALLATION

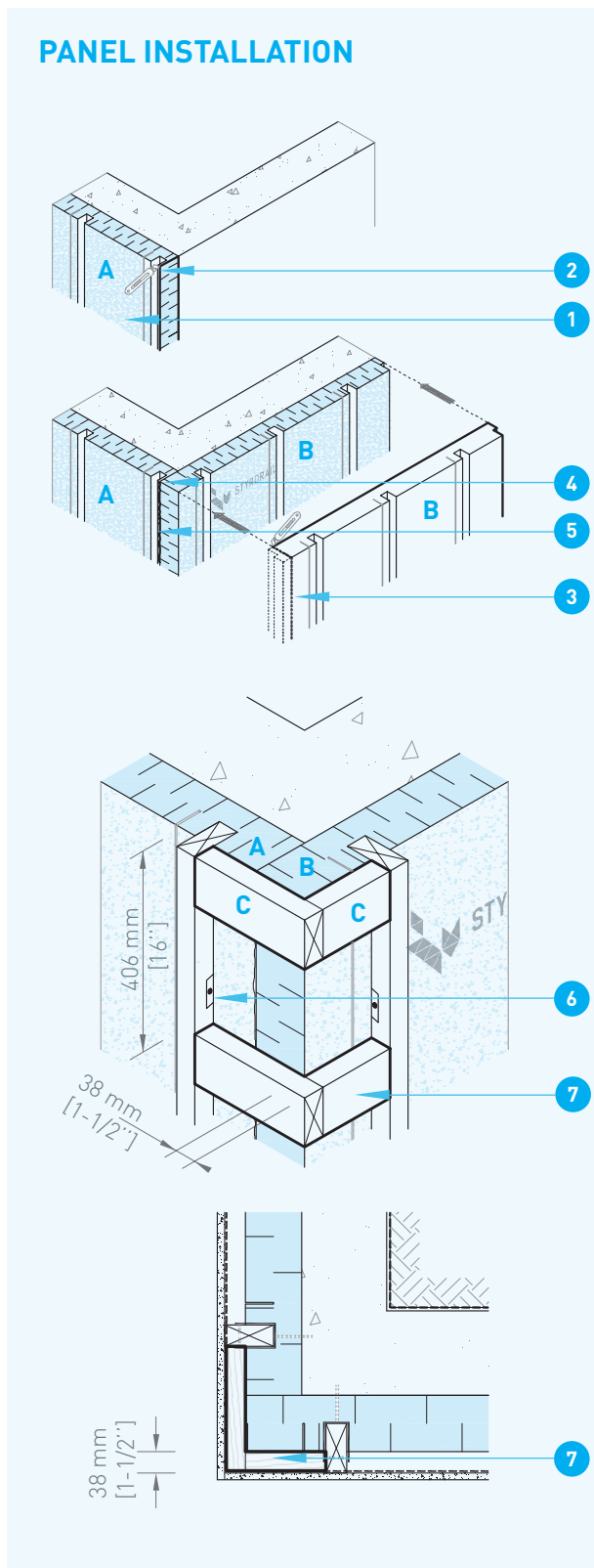

OUTSIDE CORNER

- 1 Start installation on the left side [panel A].
- 2 Cut the panel [A] to align the end of the panel with the outside corner of the foundation wall. Install the panel [A].
- 3 Cut the panel [B] on the first pre-cutline.
- 4 Install panel [B] so that the end of the panel is aligned with the exterior surface of the adjacent panel.
- 5 Spray a urethane bead⁺⁺ at the corner in order to fill the cavity which may have formed during the insulation cutting.
- 6 Install the brackets and the studs as per the installation method described in this guide.
- 7 Insert 38 mm x 89 mm [2''x4''] studs horizontally in order to serve as backing [C].
- 8 Fix wood pieces horizontally. Allow a spacing of 406 mm [16''] o.c.

JUNCTION DETAILS

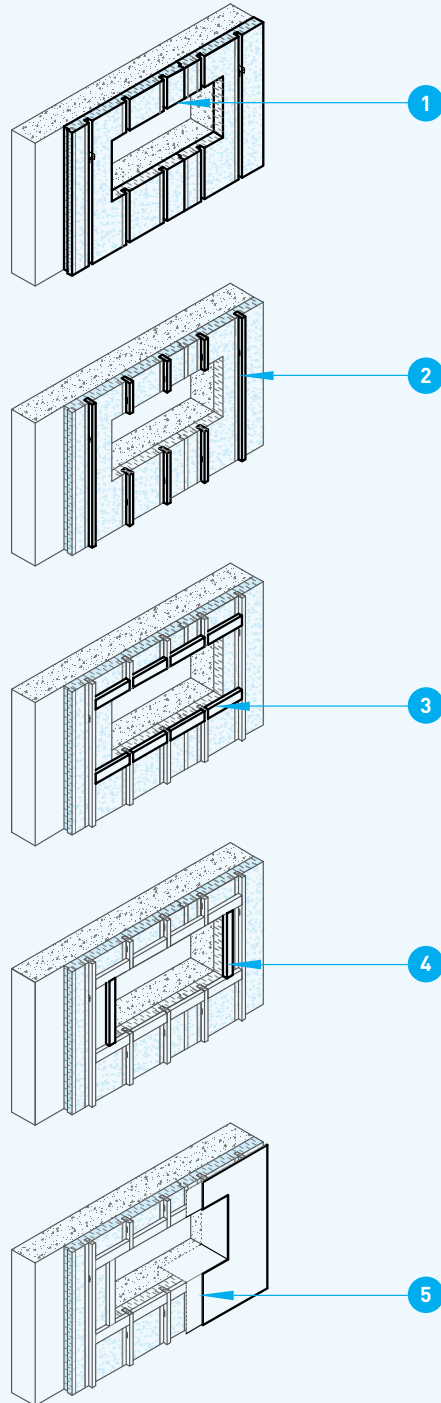

OPENING [DOOR AND WINDOW]

- 1 Cut the panels to adjust them to doors and windows gross dimensions, before they are installed. Cut panels flush to the gross opening.
- 2 Install and level the studs as per the installation method described in this guide.
- 3 Install the 38 mm x 89 mm [2"x4"'] wood pieces horizontally, at the upper and lower gross opening. Fix to vertical studs located on each side of the wood pieces.
- 4 Install the 38 mm x 89 mm [2"x4"'] studs vertically, on each side of the gross opening.
- 5 Install a vapor barrier on the panels and a protective barrier such as gypsum panels.

JUNCTION DETAILS

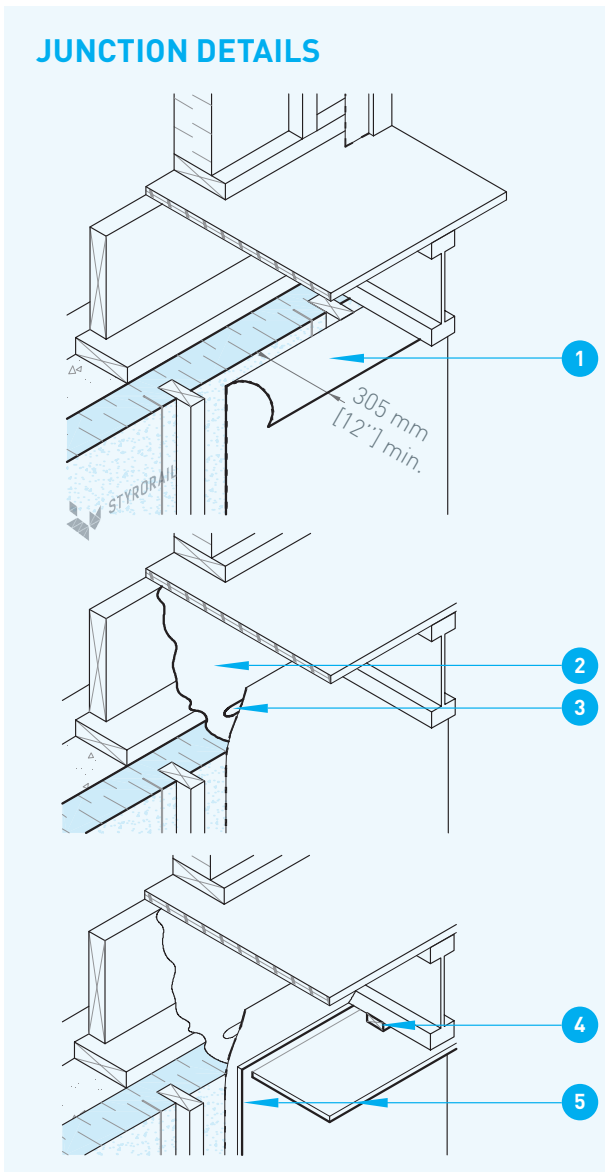

FLOOR JOIST

- 1 During the installation of the vapor barrier on the wall; leave a minimum 305 mm [12"] strip at the upper part of the wall.
- 2 Fill the cavity towards the joist header with a vapor barrier sprayed urethane.
- 3 Fold back the vapor barrier over the sprayed urethane. Fix the vapor barrier by applying an acoustic sealant bead[†].
- 4 Install furring strips underneath the floor joists.
- 5 Install a protective barrier on the wall and ceiling such as gypsum boards.

PENETRATION

[PIPE, DUCT, ELECTRICAL BOXE, ETC.]

- 1 Install electrical boxes in the space located between the insulation and the vapor barrier, next to the studs.
- 2 Install slim electrical boxes. Use airtight electric boxes.
- 3 Screw the electrical box on the stud.

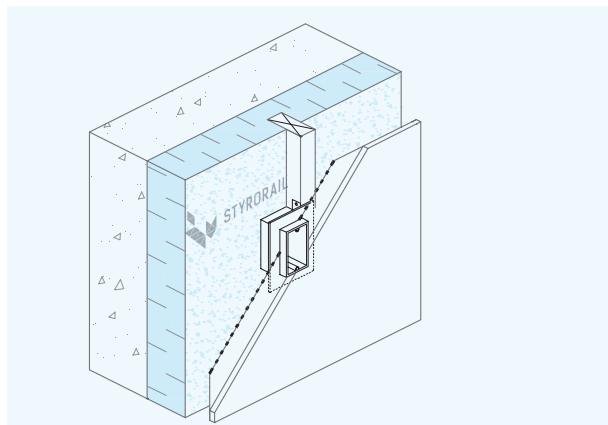

GENERAL ADVICES

RECOMMENDED PRODUCTS

† The acoustic sealant must be compatible with expanded polystyrene. Use *Tremco* acoustic sealant or equivalent.

†† Sealants must be compatible with expanded polystyrene. Use *ADFoam* from *ADFast* polyurethane insulating foam or equivalent.

STORAGE AND COVERING

Store panels in a dry and ventilated location, protected from the outside elements, ultraviolet rays, open flames or other sources of ignition. Stack panels on pallets of minimum 100 mm [4"] above the ground. If provided packaging has been damaged during shipping, cover panels with a weather and ultraviolet tarp. Panels must be dry and in good condition before installation.

EXEMPTION FROM LIABILITY

The information herein is based on the present state of our best scientific and practical knowledge. They are provided to facilitate Styro Rail™ product's installation and may not apply to all situations. The user is responsible for checking the suitability of products for their intended use. Styro Rail™ installation guides are updated on a regular basis; it is the user's responsibility to obtain and to confirm the most recent version. Information contained in this data sheet may change without notice. The drawings and details herein have not been scaled up.